

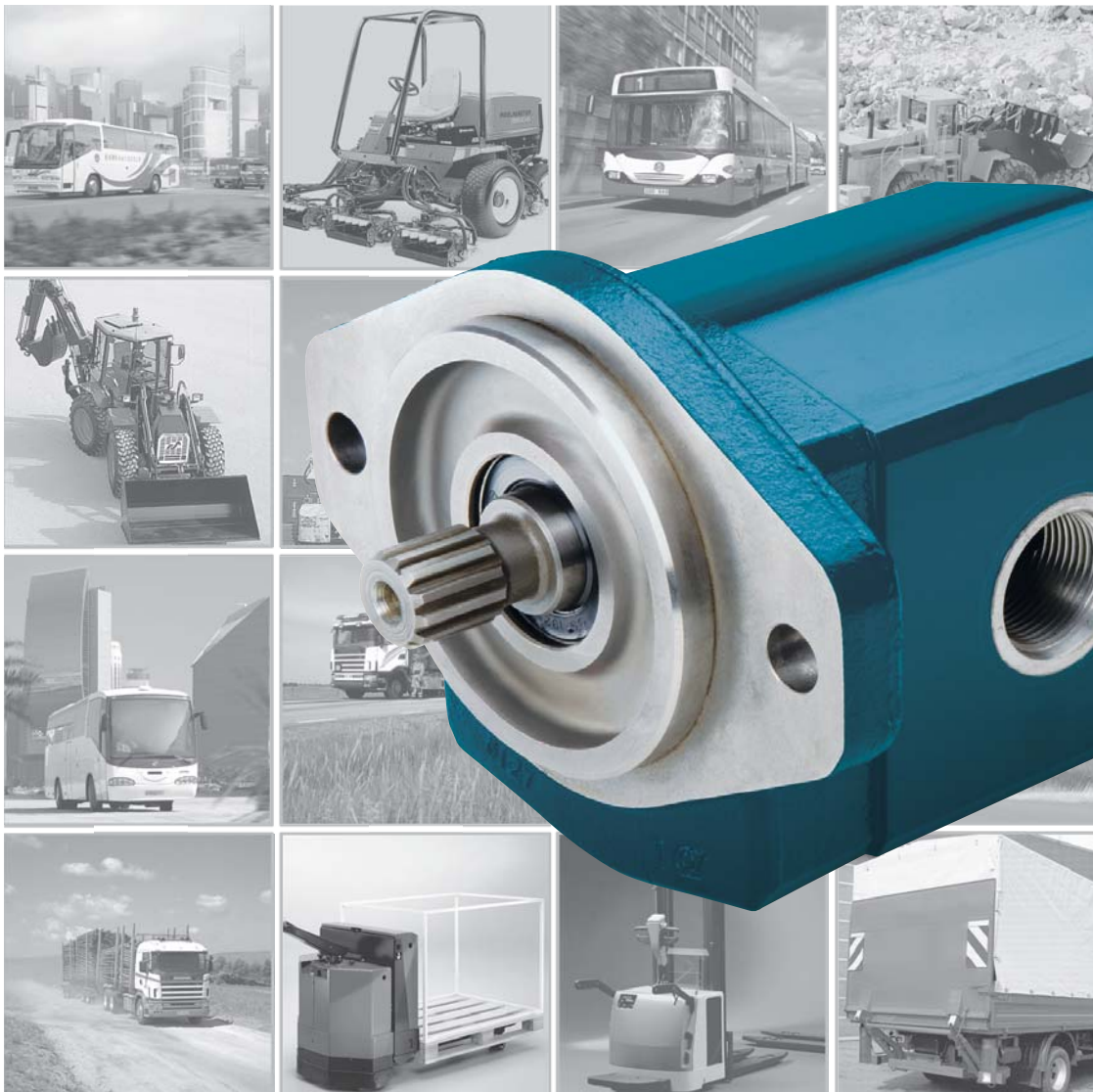

F15 Ferra Series Hydraulic Pumps



DESCRIPTION, FEATURES AND BENEFITS

Concentric F series gear pumps have an outstanding history in mobile off-highway applications. The F15 is the latest addition.

Taking the best design components from the F20/F30 series and adding new technology, Concentric has created a product of very high efficiency, yet retains the robust nature of the traditional cast iron bodied gear pump.

The gear and shaft are one piece construction for drive and driven gear providing superior resistance to fatigue and allowing the use of large diameter journals for higher load-bearing capacity. Made of high strength heat treated steel, the 14-tooth gears reduce pressure ripple (noise) and improve volumetric efficiency.

Large Teflon impregnated bushings are installed in precision bored covers for optimum alignment, providing support area capable of handling most indirect drives and fan loads.

This design uses one integrated balanced bronze pressure plate for the optimum in wear surface and strength. With an integrated "E" seal in the pressure plate, this design reduces clearance, offsets axial loading, and balances itself as pressure increases.

The F15 series can be ported in a variety of SAE, DIN, NPT, BSPP, and JIS sizes and combinations of side or rear locations.

Drive shafts in SAE splined, keyed, and taper are offered.

Mounting flanges are SAE 2-bolt "A" or 2-bolt "B" with either single or double shaft seal

configuration. The double seal option is designed for use when the pump pilot extends into a crankcase or transmission. It prevents fluid from one environment entering the other.

Pictures on front cover are used with the kind permission of eg: Atlet, BT, Huddig, Scania, Toro and Volvo Construction Equipment

TABLE OF CONTENTS

Description, Features and Benefits	2
Specifications and Application Data	3
Installation Dimensions / Model Codes	
F15	4 - 5
F1509	6 - 7
F1515	8 - 9
F151515	10 - 11
Mounting Flanges	12
Drive Shafts	13
Performance Curves	14

PERFORMANCE SPECIFICATIONS for F15 Pumps

	Theoretical Displacement Per Revolution	Continuous Rated Pressure	Max Rated Speed @ Rated Pressure & 6" Hg Vacuum Inlet	Min Rated Speed @ Rated Pressure & 6" Hg Vacuum Inlet	Typical Delivery @ Rated Speed And Pressure	Typical Delivery @ Rated Speed And Pressure	Typical Input Power @ Rated Speed And Pressure	Typical Input Power @ Rated Speed And Pressure
Model	cc / c.i.r.	bar / psi	rpm	rpm*	gpm	lpm	hp	kw
19	19 / 1.159	276 / 4000	3600	600	16.8	63.6	43.6	32.48
23	23 / 1.403	276 / 4000	3600	600	20.3	77.0	52.7	39.32
25	25 / 1.525	276 / 4000	3600	600	22.1	83.7	57.3	42.74
28	28 / 1.708	276 / 4000	3600	600	24.8	93.7	64.2	47.87
33	33 / 2.013	276 / 4000	3600	600	29.2	110.4	75.7	56.41
38	38 / 2.318	276 / 4000	3600	600	33.6	127.2	87.1	64.96
44	44 / 2.684	228 / 3300	3500	600	37.8	143.2	80.9	60.33
50	50 / 3.050	207 / 3000	3000	600	36.8	139.4	71.6	53.42

* Lower speeds are permissible when operating below rated pressure. Rated speed of double pump is governed by pump with lower speed rating. If deliveries of both pumps are combined, rated pressure is governed by pump with lower pressure rating.

Efficiency

Depending on displacement, speed and pressure, volumetric efficiency is 81-98% and overall efficiency is 71-92% with SAE 10W oil at 49°C (120°F).

Inlet conditions

Pressure on the inlet should not exceed 1 bar (15 psi). Under continuous operation, inlet vacuum should not exceed 0.17 bar (5" Hg).

Operating temperatures

Under continuous operation, a maximum of 96°C (205°F) is recommended. The maximum temperature for cyclic or intermittent operation is 107°C (225°F).

Fluids and filtration

For applications requiring fire resistant fluids, water glycols, water in-oil emulsions and synthetics can be used at slightly reduced ratings. Fluid should be selected with an operating viscosity

similar to the petroleum oil described above. For application assistance, consult your Concentric representative.

The system should be filtered to provide an ISO code (proposed) cleanliness level of 19/16. A 10 micron filter sized to accommodate full system return line flow, is recommended for most operating environments. Severe conditions may require greater efficiency from the filter.

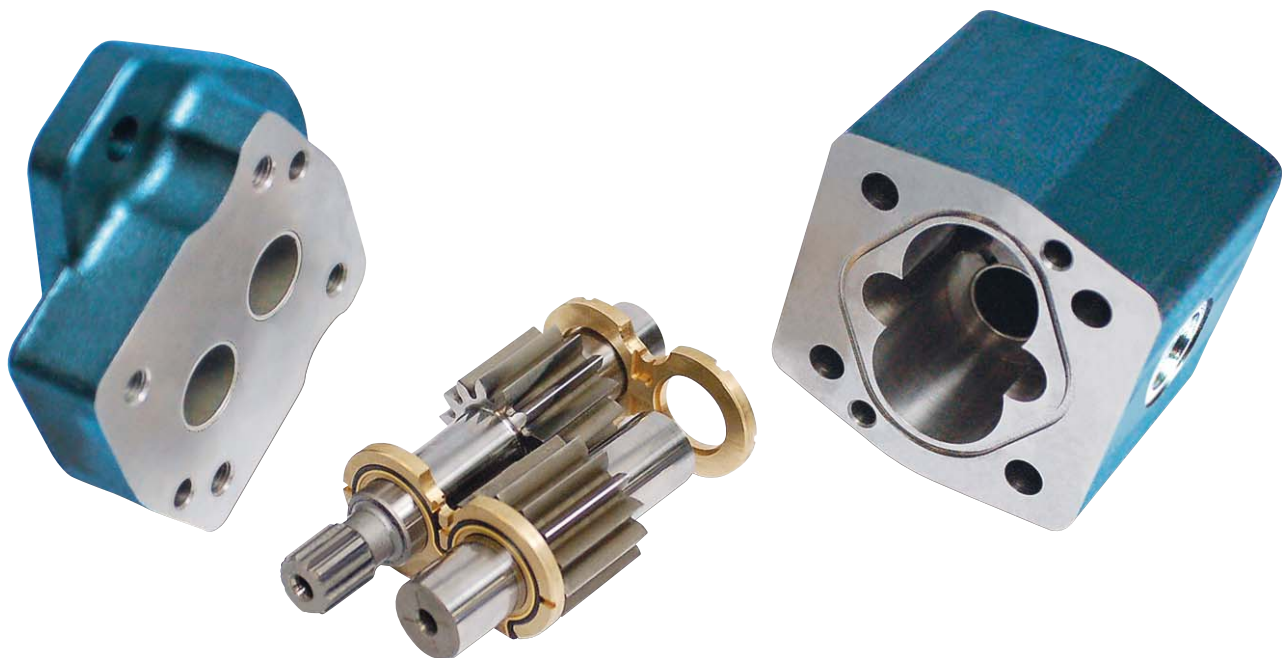

F15

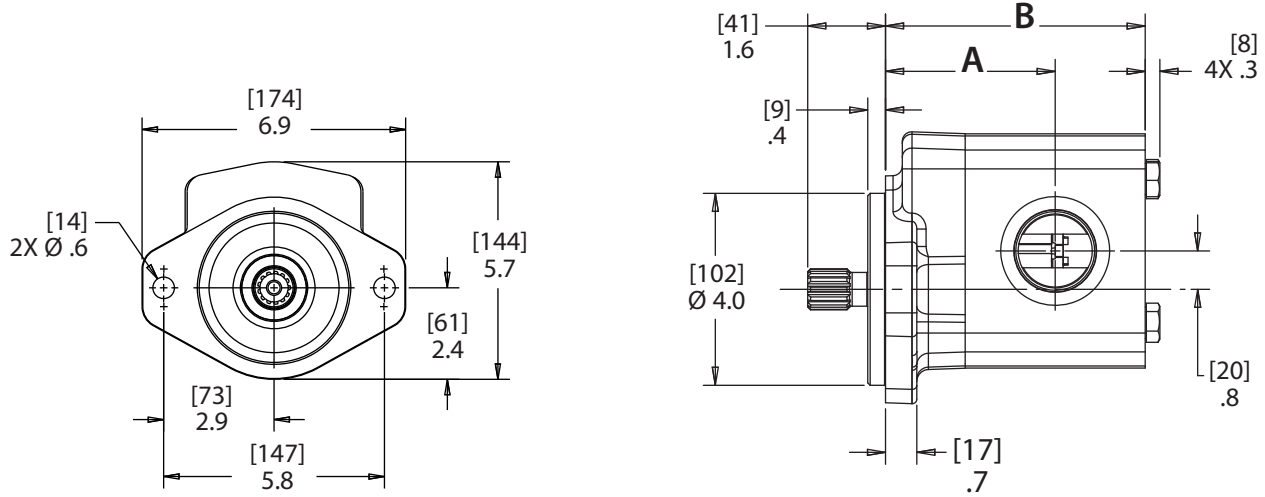

FRONT / SIDE VIEW

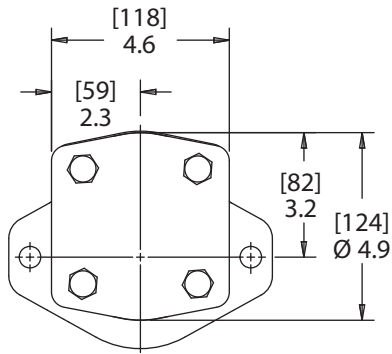

REAR / ISO VIEW

F15						
CC	CIR	DISPLACEMENT CODE	A in.	A [mm]	B in.	B [mm]
19	1.16	19	3.15	79.9	4.63	117.6
22	1.34	22	3.21	81.4	4.75	120.7
23	1.40	23	3.23	82.0	4.80	121.9
25	1.53	25	3.27	83.1	4.88	124.0
28	1.71	28	3.33	84.6	5.00	127.0
29	1.77	29	3.35	85.1	5.04	128.0
30	1.83	30	3.38	85.7	5.09	129.3
33	2.01	33	3.44	87.2	5.21	132.3
35	2.14	35	3.48	88.3	5.29	134.4
38	2.32	38	3.54	89.8	5.41	137.4
44	2.68	44	3.66	93.0	5.66	143.8
50	3.05	50	3.78	96.0	5.90	149.9

All dimensions shown are for single shaft seal version and "for reference only". Consult factory for your specific configuration.

Model Code for F15 Ferra Series Single Pumps

ORDERING INFORMATION

Each option has been assigned an order code -- listed in the tables below -- for placement in the sequence shown at right.

1 (Special Seals)

Order Code	Description
F3	Viton Seal
Omit	Standard

2 (Series)

Order Code	Description
F15	F15 Ferra Series Single Gear Pump

3 (Mount Type)

Order Code	Description
S	Single Shaft Seal
W	Wet Mount (Double Shaft Seal)

4 (Front Cover)

Order Code	Description
1	SAE "A" 2-Bolt Mount (consult factory)
2	SAE "B" 2-Bolt Mount
8	SAE "C" 2/4-Bolt Combination Mount (consult factory)

5 (Inlet Port)

Order Code	Description
B	1.00", SAE 4-Bolt Split Flange
C	1.25", SAE 4-Bolt Split Flange
D	1.50", SAE 4-Bolt Split Flange
DM	1.50", SAE 4-Bolt Metric Split Flange (M14 x 2.0" threads)
V	#16 SAE (1 5/16" - 12) O-Ring
W	#20 SAE (1 5/8" - 12) O-Ring
X	#24 SAE (1 7/8" - 12) O-Ring

Contact factory for other requirements.

6 (Displacements)

Order Code	Cm ³ /In ³	Order Code	Cm ³ /In ³
19	19 cc/1.16 in. ³	38	38 cc/2.32 in. ³
23	23 cc/1.40 in. ³	44	44 cc/2.68 in. ³
25	25 cc/1.53 in. ³	50	50 cc/3.05 in. ³
28	28 cc/1.71 in. ³		
33	33 cc/2.01 in. ³		

7 (Outlet Port)

Order Code	Description
A	.750", SAE 4-Bolt Split Flange
B	1.00", SAE 4-Bolt Split Flange
BM	1.00", SAE 4-Bolt Metric Split Flange (M10 x 1.50" threads)
S	#10 SAE (.875" - 14) O-Ring
T	#12 SAE (1 1/16" - 12) O-Ring
V	#16 SAE (1 5/16" - 12) O-Ring

Contact factory for other requirements.

8 (Rear Cover)

Order Code	Description
1	Standard Single Pump Rear Cover (no options)

9 (Shaft Seal)

Order Code	Description
A	Single Shaft Seal (30 PSI)
B	Double Shaft Seal (30 PSI) (W mount type only)
C	None
D	High Pressure (150 PSI)

EXAMPLE:

(F3)-	F15-	W-	2 - D-	19-	B - 1-	A - 12-	A-	10-	L			
1	2	3	4	5	6	7	8	9	10	11	12	13
Special Seals	Ferra Series	Mount Type	Front Cover	Inlet Port	Displacements	Outlet Port	Rear Cover	Shaft Seal	Drive Shaft	Port Locations	Design	Rotation

10 (Drive Shaft)

Order Code	Description
1	SAE "B" Straight Keyed, .875" Diameter, 1.3125" Ext.
5	Tapered Threaded (1.50" taper per foot)
7	Tapered Keyed/Threaded (.625" - 18 UNC, 1.50" taper per foot)
11	SAE "B" 13-Tooth Spline, Major Dia. Fit
12	SAE "B" 13-Tooth Spline, Flat Root-Side Fit
15	SAE "A" 11-Tooth Spline
19	SAE "A" 9-Tooth Spline
21	SAE "BB" Straight Keyed, 1.00" diameter, 1.50" ext.
99	SAE "BB" 15-Tooth Spline, Flat Root-Side Fit

Contact factory for other requirements.

11 (Port Locations)

Order Code	Description
A	Side Inlet / Side Outlet
B	Side Inlet / Rear Outlet (consult factory)
C	Rear Inlet / Side Outlet (consult factory)
D	Rear Inlet / Rear Outlet (consult factory)

12 (Design Designation)

Order Code	Description
10	Standard

13 (Rotation)

Order Code	Description
L	Counterclockwise Rotation
R	Clockwise Rotation

F1509

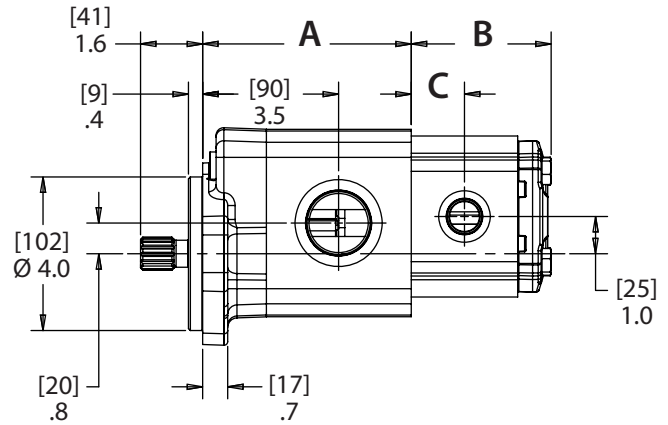
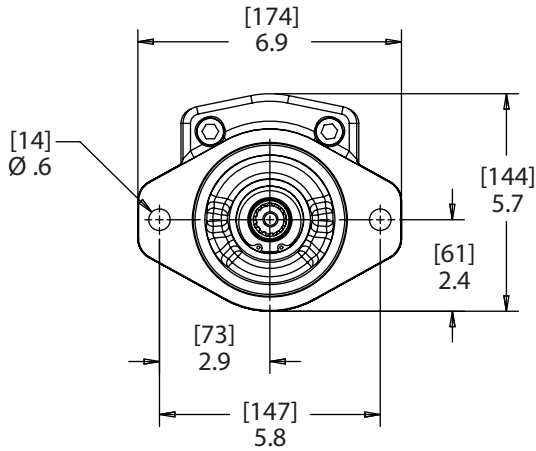

FRONT / SIDE VIEW

F15 SECTION

CC	CIR	DISPLACEMENT CODE	A in.	A [mm]
19	1.16	19	4.7	118
22	1.34	22	4.8	121
23	1.40	23	4.8	122
25	1.53	25	4.9	125
28	1.71	28	5.0	128
29	1.77	29	5.1	129
30	1.83	30	5.1	130
33	2.01	33	5.2	133
35	2.14	35	5.3	135
38	2.32	38	5.4	138
44	2.68	44	5.7	144
50	3.05	50	5.9	150

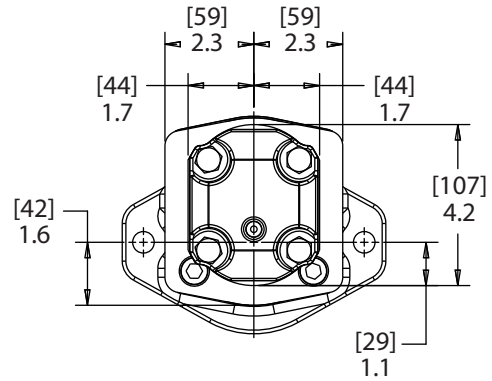

REAR VIEW

W900 SECTION

CC	CIR	DISPLACEMENT CODE	B in.	B [mm]	C in.	C [mm]
6	0.37	6	2.9	73	1.0	26
8	1.49	8	3.0	76	1.1	27
10	0.61	10	3.1	79	1.1	29
11	0.67	11	3.2	81	1.2	29
14	0.85	14	3.4	85	1.2	32
16	0.98	16	3.5	88	1.3	33
19	1.16	19	3.6	93	1.4	35
23	1.40	23	3.9	98	1.5	38
27	1.65	27	4.1	104	1.6	41
28	1.71	28	4.2	106	1.6	42

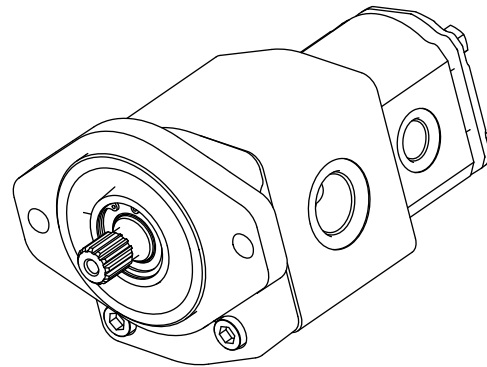

ISO VIEW

All dimensions shown are for reference only. Consult factory for your specific configuration.

Model Code for F1509 Ferra Series Tandem Pumps

ORDERING INFORMATION

Each option has been assigned an order code -- listed in the tables below -- for placement in the sequence shown at right.

1 (Special Seals)

Order Code	Description
F3	Viton Seal
Omit	Standard

2 (Series)

Order Code	Description
F1509	F15 / W900 Ferra Series Tandem Pump

3 (Mount Type)

Order Code	Description
S	Single Shaft Seal
W	Wet Mount (Double Shaft Seal)

4 (Front Cover)

Order Code	Description
1	SAE "A" 2-Bolt Mount (consult factory)
2	SAE "B" 2-Bolt Mount
8	SAE "C" 2/4-Bolt Combination Mount (consult factory)

5 (Front Section Inlet Port)

Order Code	Description
B	1.00", SAE 4-Bolt Split Flange
C	1.25", SAE 4-Bolt Split Flange
D	1.50", SAE 4-Bolt Split Flange
DM	1.50", SAE 4-Bolt Metric Split Flange (M14 x 2.0" threads)
V	#16 SAE (1 5/16" - 12) O-Ring
W	#20 SAE (1 5/8" - 12) O-Ring
X	#24 SAE (1 7/8" - 12) O-Ring

Contact factory for other requirements.

6 (Front Section Displacements)

Order Code	Cm ³ /In ³	Order Code	Cm ³ /In ³
19	19 cc/1.16 in. ³	38	38 cc/2.32 in. ³
23	23 cc/1.40 in. ³	44	44 cc/2.68 in. ³
25	25 cc/1.53 in. ³	50	50 cc/3.05 in. ³
28	28 cc/1.71 in. ³		
33	33 cc/2.01 in. ³		

7 (Front Section Outlet Port)

Order Code	Description
A	.750", SAE 4-Bolt Split Flange
B	1.00", SAE 4-Bolt Split Flange
BM	1.00", SAE 4-Bolt Metric Split Flange (M10 x 1.50" threads)
S	#10 SAE (.875" - 14) O-Ring
T	#12 SAE (1 1/16" - 12) O-Ring
V	#16 SAE (1 5/16" - 12) O-Ring

Contact factory for other requirements.

8 (Rear Section Inlet Port)

Order Code	Description
A	16 cc - 19 cc, .75", SAE 4-Bolt Split Flange
B	23 cc - 28 cc, 1", SAE 4-Bolt Split Flange
S	6 cc, #10 SAE (7/8"-14) Straight Thread
T	8 cc - 16 cc, #12 SAE (1-1/16"-12) Straight Thread
V	19 cc - 28 cc, #16 SAE (1-5/16"-12) Straight Thread
X	No Rear Inlet Port (Single Inlet for Double Pump)

Dual inlet for double pump. Split flange ports are not available for 6 cc - 14 cc sizes. Metric ports available, contact factory.

9 (Rear Section Displacements)

Order Code	Cm ³ /In ³	Order Code	Cm ³ /In ³
6	6 cc/.366 in. ³	16	16 cc/.976 in. ³
8	8 cc/.488 in. ³	19	19 cc/1.159 in. ³
10	10 cc/.610 in. ³	23	23 cc/1.403 in. ³
11	11 cc/.671 in. ³	27	27 cc/1.647 in. ³
14	14 cc/.854 in. ³	28	28 cc/1.709 in. ³

EXAMPLE:

(F3)- F1509- W- 2 - C- 19- B - A -11- Q- 12- A- 10- L													
1	2	3	4	5	6	7	8	9	10	11	12	13	14
Special Seals	Ferra Series	Mount	Front Cover	Front Section Inlet	Displacements	Front Section Outlet	Rear Section Inlet	Displacements	Rear Section Outlet	Drive Shaft	Shaft Seal	Design Designation	Rotation

10 (Rear Section Outlet Porting)

Order Code	Description
A	23 cc -28 cc, .750", SAE 4-Bolt Split Flange
Q	6 cc, #8 SAE (3/4"-16) Straight Thread
S	8 cc - 16 cc, #10 SAE (.875" - 14) Straight Thread
T	19 cc - 28 cc, #12 SAE (1 1/16" - 12) Straight Thread
Y	16 cc - 19 cc, .5", SAE 4-Bolt Split Flange

Contact factory for other requirements.

11 (Drive Shaft)

Order Code	Description
1	SAE "B" Straight Keyed, .875" Diameter, 1.3125" Ext.
11	SAE "B" 13-Tooth Spline, Major Dia. Fit
12	SAE "B" 13-Tooth Spline, Flat Root-Side Fit
15	SAE "A" 11-Tooth Spline
19	SAE "A" 9-Tooth Spline
21	SAE "BB" Straight Keyed, 1.00" Dia.
99	SAE "BB" 15-Tooth Spline, Flat Root-Side Fit

Contact factory for other requirements.

12 (Shaft Seal)

Order Code	Description
A	Single Shaft Seal (30 PSI)
B	Double Shaft Seal (30 PSI) (W mount type only)
C	None
D	High Pressure (150 PSI)

13 (Design Designation)

Order Code	Description
10	Standard
11	Seal Between Sections

14 (Rotation)

Order Code	Description
L	Counterclockwise Rotation
R	Clockwise Rotation

F1515

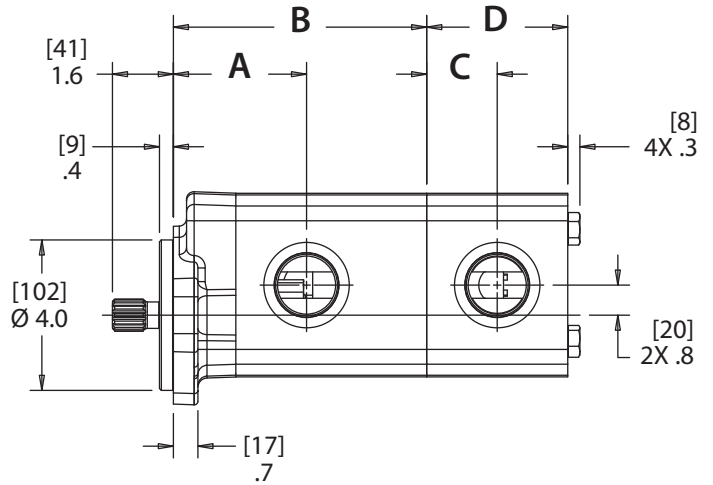
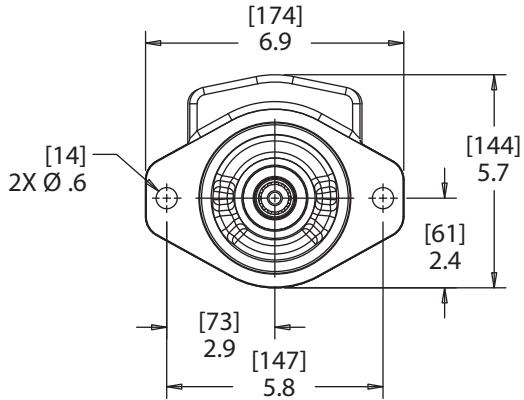

FRONT / SIDE VIEW

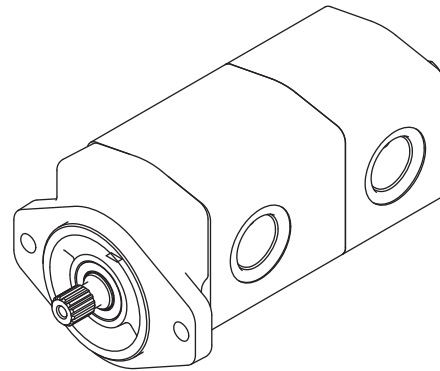
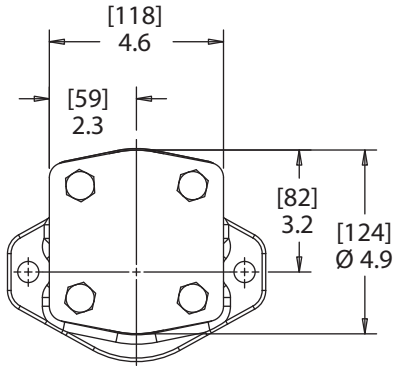

REAR / ISO VIEW

F1515										
CC	CIR	DISPLACEMENT CODE	A in.	A [mm]	B in.	B [mm]	C in.	C [mm]	D in.	D [mm]
19	1.16	19	3.2	80	6.0	151	1.5	38	3.0	75
22	1.34	22	3.2	82	6.1	154	1.6	39	3.1	78
23	1.40	23	3.2	82	6.1	155	1.6	40	3.1	80
25	1.53	25	3.3	83	6.2	158	1.6	41	3.2	82
28	1.71	28	3.3	85	6.3	161	1.7	42	3.3	85
29	1.77	29	3.4	85	6.4	162	1.7	43	3.4	86
30	1.83	30	3.4	86	6.4	163	1.7	44	3.4	87
33	2.01	33	3.4	87	6.5	166	1.8	45	3.6	90
35	2.14	35	3.5	88	6.6	168	1.8	46	3.6	92
38	2.32	38	3.5	90	6.7	171	1.9	48	3.8	95
44	2.68	44	3.7	93	7.0	177	2.0	51	4.0	102
50	3.05	50	3.8	96	7.2	183	2.1	54	4.2	108

All dimensions shown are for reference only. Consult factory for your specific configuration.

Model Code for F1515 Ferra Series Tandem Pumps

ORDERING INFORMATION

Each option has been assigned an order code -- listed in the tables below -- for placement in the sequence shown at right.

1 (Special Seals)

Order Code	Description
F3	Viton Seal
Omit	Standard

2 (Series)

Order Code	Description
F1515	F15 / F15 Ferra Series Tandem Pump

3 (Mount Type)

Order Code	Description
S	Single Shaft Seal
W	Wet Mount (Double Shaft Seal)

4 (Front Cover)

Order Code	Description
1	SAE "A" 2-Bolt Mount (consult factory)
2	SAE "B" 2-Bolt Mount
8	SAE "C" 2/4-Bolt Combination Mount (consult factory)

5 (Front Section Inlet Port)

Order Code	Description
B	1.00", SAE 4-Bolt Split Flange
C	1.25", SAE 4-Bolt Split Flange
D	1.50", SAE 4-Bolt Split Flange
DM	1.50", SAE 4-Bolt Metric Split Flange (M14 x 2.0" threads)
V	#16 SAE (1 5/16" - 12) O-Ring
W	#20 SAE (1 5/8" - 12) O-Ring
X	#24 SAE (1 7/8" - 12) O-Ring

Contact factory for other requirements.

6 (Front Section Displacements)

Order Code	Cm ³ /In ³	Order Code	Cm ³ /In ³
19	19 cc/1.16 in. ³	38	38 cc/2.32 in. ³
23	23 cc/1.40 in. ³	44	44 cc/2.68 in. ³
25	25 cc/1.53 in. ³	50	50 cc/3.05 in. ³
28	28 cc/1.71 in. ³		
33	33 cc/2.01 in. ³		

7 (Front Section Outlet Port)

Order Code	Description
A	.750", SAE 4-Bolt Split Flange
B	1.00", SAE 4-Bolt Split Flange
BM	1.00", SAE 4-Bolt Metric Split Flange (M10 x 1.50" threads)
S	#10 SAE (.875" - 14) O-Ring
T	#12 SAE (1 1/16" - 12) O-Ring
V	#16 SAE (1 5/16" - 12) O-Ring

Contact factory for other requirements.

8 (Rear Section Inlet Port)

Order Code	Description
B	1.00", SAE 4-Bolt Split Flange
C	1.25", SAE 4-Bolt Split Flange
D	1.50", SAE 4-Bolt Split Flange
DM	1.50", SAE 4-Bolt Metric Split Flange (M14 x 2.0" threads)
V	#16 SAE (1 5/16" - 12) O-Ring
W	#20 SAE (1 5/8" - 12) O-Ring
X	#24 SAE (1 7/8" - 12) O-Ring

Contact factory for other requirements.

9 (Rear Section Displacements)

Order Code	Cm ³ /In ³	Order Code	Cm ³ /In ³
08	3.8 cc/.23 in. ³	28	13.3 cc/.81 in. ³
12	5.7 cc/.35 in. ³	32	15.2 cc/.93 in. ³
16	7.6 cc/.47 in. ³	36	17.1 cc/1.04 in. ³
20	9.5 cc/.58 in. ³		
24	11.4 cc/.70 in. ³		

Contact factory for single inlet applications.

EXAMPLE:

(F3)-F1515- W- 2 - C-19-B - D -25- A-12- A- 10- L													
1	2	3	4	5	6	7	8	9	10	11	12	13	14
Special Seals	Ferra Series	Mount	Front Cover	Front Section Inlet	Displacements	Front Section Outlet	Rear Section Inlet	Displacements	Rear Section Outlet	Drive Shaft	Shaft Seal	Design Designation	Rotation
F3	F1515	W	2	C	19	B	D	25	A	12	A	10	L

10 (Rear Section Outlet Port)

Order Code	Description
A	.750", SAE 4-Bolt Split Flange
B	1.00", SAE 4-Bolt Split Flange
BM	1.00", SAE 4-Bolt Metric Split Flange (M10 x 1.50" threads)
S	#10 SAE (7/8"-14) Straight Thread
T	#12 SAE (1-1/16"-12) Straight Thread
V	#16 SAE (1-5/16"-12) Straight Thread

11 (Drive Shaft)

Order Code	Description
1	SAE "B" Straight Keyed, .875" Diameter, 1.3125" Ext.
11	SAE "B" 13-Tooth Spline, Major Dia. Fit
12	SAE "B" 13-Tooth Spline, Flat Root-Side Fit
15	SAE "A" 11-Tooth Spline
19	SAE "A" 9-Tooth Spline
21	SAE "BB" Straight Keyed, 1.00" diameter, 1.50" ext.
99	SAE "BB" 15-Tooth Spline, Flat Root-Side Fit

Contact factory for other requirements.

12 (Shaft Seal)

Order Code	Description
A	Single Shaft Seal (30 PSI)
B	Double Shaft Seal (30 PSI) (W mount type only)
C	None
D	High Pressure (150 PSI)

13 (Design Designation)

Order Code	Description
10	Standard
11	Seal Between Sections

14 (Rotation)

Order Code	Description
L	Counterclockwise Rotation
R	Clockwise Rotation

F151515

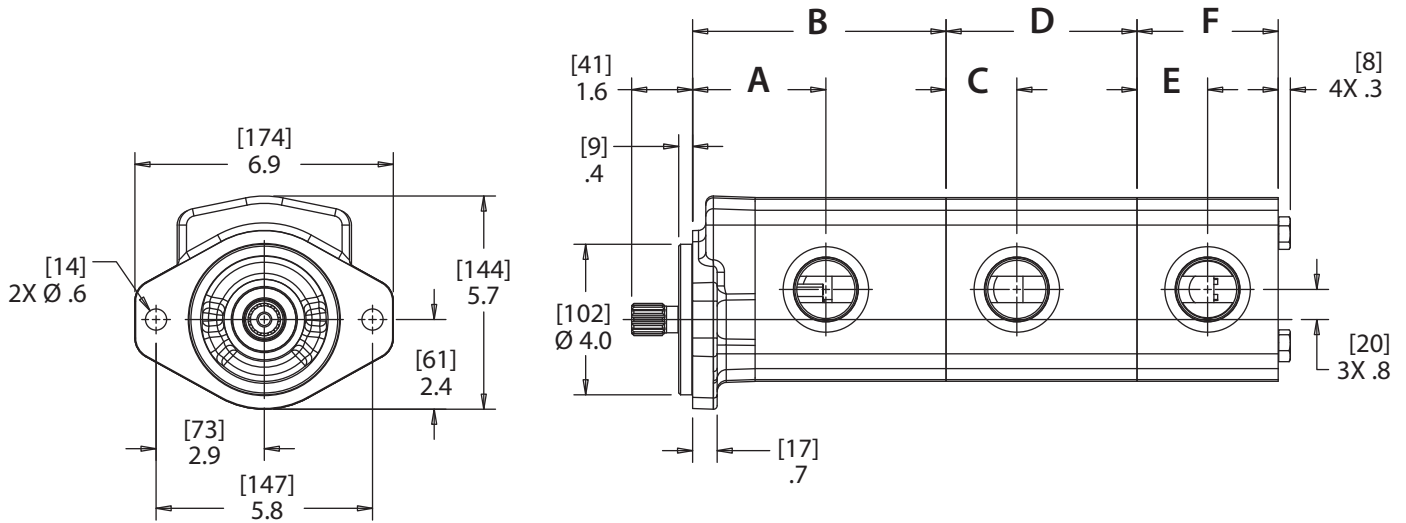

FRONT / SIDE VIEW

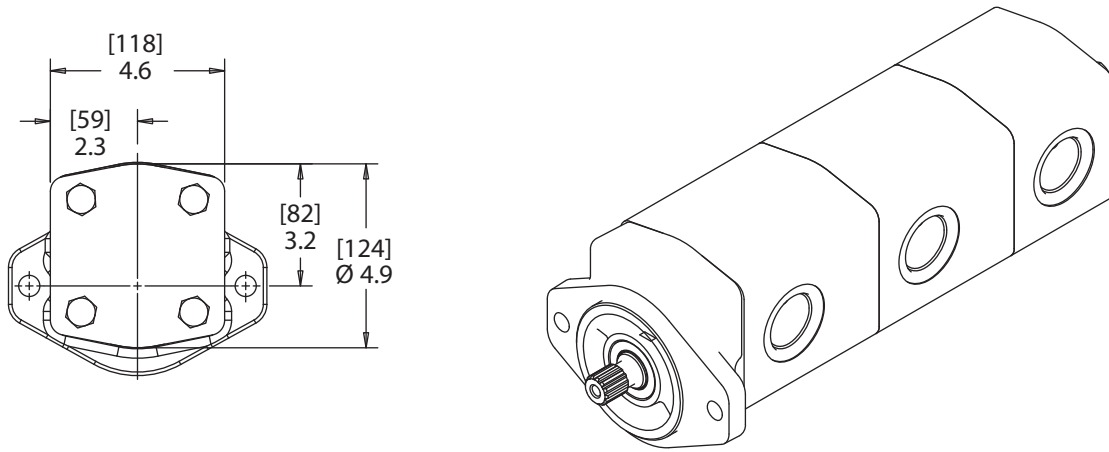

REAR / ISO VIEW

All dimensions shown are for reference only. Consult factory for your specific configuration.

F151515														
CC	CIR	DISPLACEMENT CODE	A in.	A [mm]	B in.	B [mm]	C in.	C [mm]	D in.	D [mm]	E in.	E [mm]	F in.	F [mm]
19	1.16	19	3.2	80	6.0	151	1.5	38	4.3	109	1.5	38	3.0	75
22	1.34	22	3.2	82	6.1	154	1.6	39	4.4	112	1.6	39	3.1	78
23	1.40	23	3.2	82	6.1	155	1.6	40	4.5	113	1.6	40	3.1	80
25	1.53	25	3.3	83	6.2	158	1.6	41	4.5	115	1.6	41	3.2	82
28	1.71	28	3.3	85	6.3	161	1.7	42	4.7	118	1.7	42	3.3	85
29	1.77	29	3.4	85	6.4	162	1.7	43	4.7	120	1.7	43	3.4	86
30	1.83	30	3.4	86	6.4	163	1.7	44	4.7	121	1.7	44	3.4	87
33	2.01	33	3.4	87	6.5	166	1.8	45	4.9	124	1.8	45	3.6	90
35	2.14	35	3.5	88	6.6	168	1.8	46	5.0	126	1.8	46	3.6	92
38	2.32	38	3.5	90	6.7	171	1.9	48	5.1	129	1.9	48	3.8	95
44	2.68	44	3.7	93	7.0	177	2.0	51	5.3	135	2.0	51	4.0	102
50	3.05	50	3.8	96	7.2	183	2.1	54	5.6	141	2.1	54	4.2	108

Model Code for F151515 Ferra Series Triple Pumps

ORDERING INFORMATION

Each option has been assigned an order code -- listed in the tables below -- for placement in the sequence shown at right.

1 (Special Seals)

Order Code	Description
F3	Viton Seal
Omit	Standard

2 (Series)

Order Code	Description
F151515	F15 / F15 / F15 Ferra Series Triple Pump

3 (Mount Type)

Order Code	Description
S	Single Shaft Seal
W	Wet Mount (Double Shaft Seal)

4 (Front Cover)

Order Code	Description
1	SAE "A" 2-Bolt Mount (consult factory)
2	SAE "B" 2-Bolt Mount
8	SAE "C" 2/4-Bolt Combination Mount (consult factory)

5 (Front Section Inlet Port)

Order Code	Description
B	1.00", SAE 4-Bolt Split Flange
C	1.25", SAE 4-Bolt Split Flange
D	1.50", SAE 4-Bolt Split Flange
DM	1.50", SAE 4-Bolt Metric Split Flange (M14 x 2.0" threads)
V	#16 SAE (1 5/16" - 12) O-Ring
W	#20 SAE (1 5/8" - 12) O-Ring
X	#24 SAE (1 7/8" - 12) O-Ring

Contact factory for other requirements.

6 (Front Section Displacements)

Order Code	Cm ³ /In ³	Order Code	Cm ³ /In ³
19	19 cc/1.16 in. ³	38	38 cc/2.32 in. ³
23	23 cc/1.40 in. ³	44	44 cc/2.68 in. ³
25	25 cc/1.53 in. ³	50	50 cc/3.05 in. ³
28	28 cc/1.71 in. ³		
33	33 cc/2.01 in. ³		

7 (Front Section Outlet Port)

Order Code	Description
A	.750", SAE 4-Bolt Split Flange
B	1.00", SAE 4-Bolt Split Flange
BM	1.00", SAE 4-Bolt Metric Split Flange (M10 x 1.50" threads)
S	#10 SAE (.875" - 14) O-Ring
T	#12 SAE (1 1/16" - 12) O-Ring
V	#16 SAE (1 5/16" - 12) O-Ring

Contact factory for other requirements.

8 (Rear Section Inlet Port)

Order Code	Description
B	1.00", SAE 4-Bolt Split Flange
C	1.25", SAE 4-Bolt Split Flange
D	1.50", SAE 4-Bolt Split Flange
DM	1.50", SAE 4-Bolt Metric Split Flange (M14 x 2.0" threads)
V	#16 SAE (1 5/16" - 12) O-Ring
W	#20 SAE (1 5/8" - 12) O-Ring
X	#24 SAE (1 7/8" - 12) O-Ring

Contact factory for other requirements.

9 (Second Section Displacements)

Order Code	Cm ³ /In ³	Order Code	Cm ³ /In ³
19	19 cc/1.16 in. ³	38	38 cc/2.32 in. ³
23	23 cc/1.40 in. ³	44	44 cc/2.68 in. ³
25	25 cc/1.53 in. ³	50	50 cc/3.05 in. ³
28	28 cc/1.71 in. ³		
33	33 cc/2.01 in. ³		

* Contact factory for other requirements. See #14 Drive Shaft.

EXAMPLE:

1	2	3	4	5	6	7	8	9	10	11	12	13	14	15	16	17
(F3)	F151515	W	2	C	19	B	D	25	V	X	25	A	1	B	10	L
Special Seals	Ferra Series	Mount	Front Cover	Front Section Inlet	Displacements	Front Section Outlet	Rear Section Inlet	Displacements	2nd Section Outlet	3rd Section Inlet	Displacements	3rd Section Outlet	Drive Shaft	Shaft Seal	Design Designation	Rotation

10 (Second Section Outlet Port)

Order Code	Description
A	.750", SAE 4-Bolt Split Flange
B	1.00", SAE 4-Bolt Split Flange
BM	1.00", SAE 4-Bolt Metric Split Flange (M10 x 1.50" threads)
S	#10 SAE (7/8" - 14) Straight Thread
T	#12 SAE (1-1/16" - 12) Straight Thread
V	#16 SAE (1-5/16" - 12) Straight Thread

11 (Third Section Inlet Port)

Order Code	Description
B	1.00", SAE 4-Bolt Split Flange
C	1.25", SAE 4-Bolt Split Flange
D	1.50", SAE 4-Bolt Split Flange
DM	1.50", SAE 4-Bolt Metric Split Flange (M14 x 2.0" threads)
V	#16 SAE (1 5/16" - 12) O-Ring
W	#20 SAE (1 5/8" - 12) O-Ring
X	#24 SAE (1 7/8" - 12) O-Ring

Contact factory for other requirements.

12 (Third Section Displacements)

Order Code	Cm ³ /In ³	Order Code	Cm ³ /In ³
19	19 cc/1.16 in. ³	38	38 cc/2.32 in. ³
23	23 cc/1.40 in. ³	44	44 cc/2.68 in. ³
25	25 cc/1.53 in. ³	50	50 cc/3.05 in. ³
28	28 cc/1.71 in. ³		
33	33 cc/2.01 in. ³		

13 (Third Section Outlet Port)

Order Code	Description
A	.750", SAE 4-Bolt Split Flange
B	1.00", SAE 4-Bolt Split Flange
BM	1.00", SAE 4-Bolt Metric Split Flange (M10 x 1.50" threads)
S	#10 SAE (7/8" - 14) Straight Thread
T	#12 SAE (1-1/16" - 12) Straight Thread
V	#16 SAE (1-5/16" - 12) Straight Thread

14 (Drive Shaft)*

Order Code	Description
1	SAE "B" Straight Keyed, .875" Diameter, 1.3125" Ext.
12	SAE "B" 13-Tooth Spline, Flat Root-Side Fit
21	SAE "BB" Straight Keyed, 1.00" diameter, 1.50" ext.
99	SAE "BB" 15-Tooth Spline, Flat Root-Side Fit

15 (Shaft Seal)

Order Code	Description
A	Single Shaft Seal (30 PSI)
B	Double Shaft Seal (30 PSI) (W mount type only)
C	None
D	High Pressure (150 PSI)

16 (Design Designation)

Order Code	Description
10	Standard
11	Seal Between Sections

17 (Rotation)

Order Code	Description
L	Counterclockwise Rotation
R	Clockwise Rotation

MOUNTING FLANGES

SAE "A" 2-BOLT

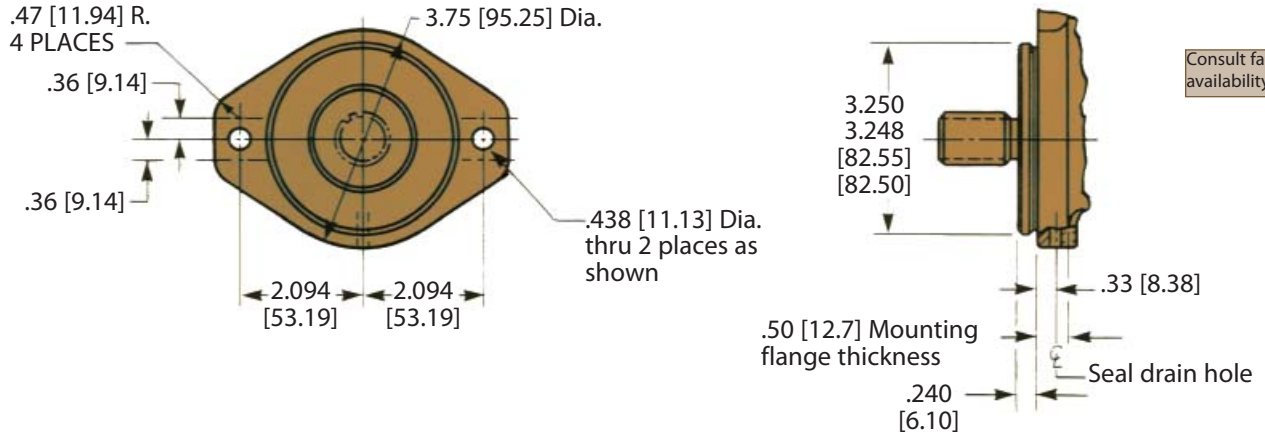

SAE "B" 2-BOLT

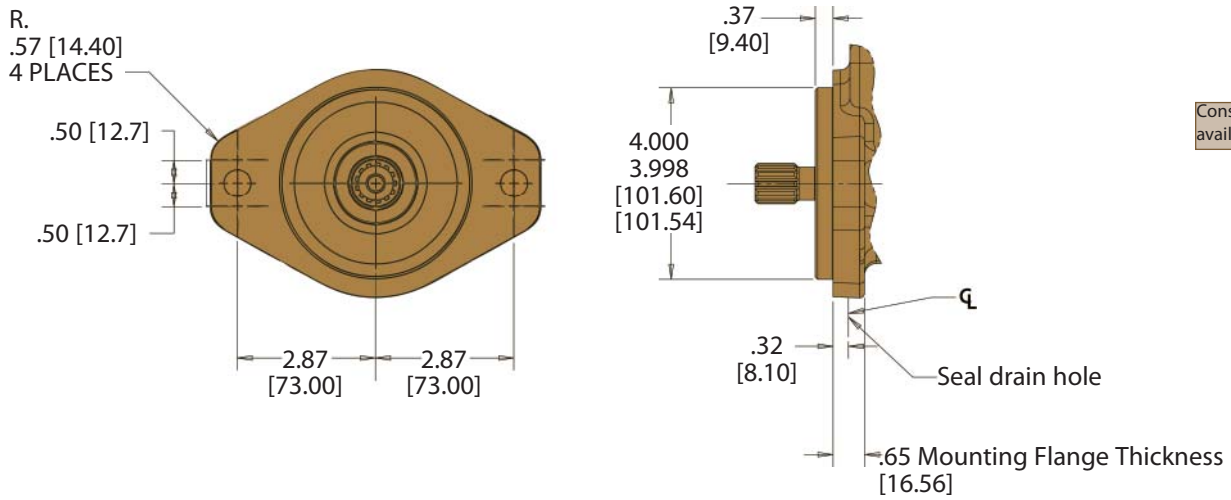

SAE C 2/4-BOLT

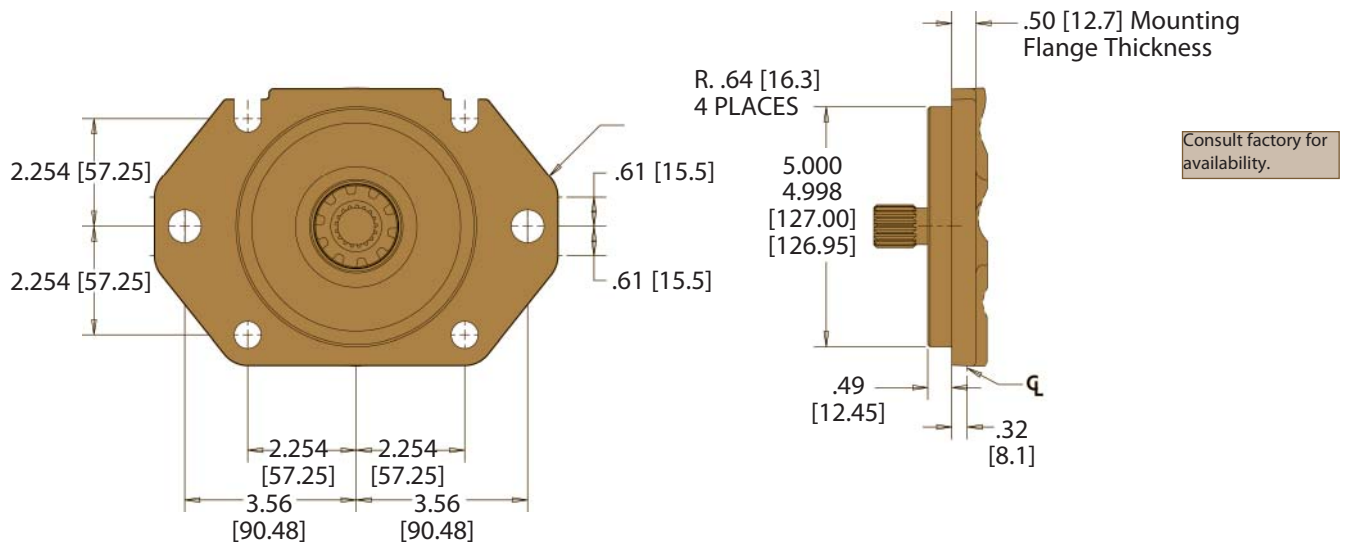

DRIVE SHAFTS

SAE "B" STRAIGHT KEY

Shaft No. 1: For F15, F1509 & F1515 Pumps
292.6 Nm (2590 in. lb.) torsional capacity.*

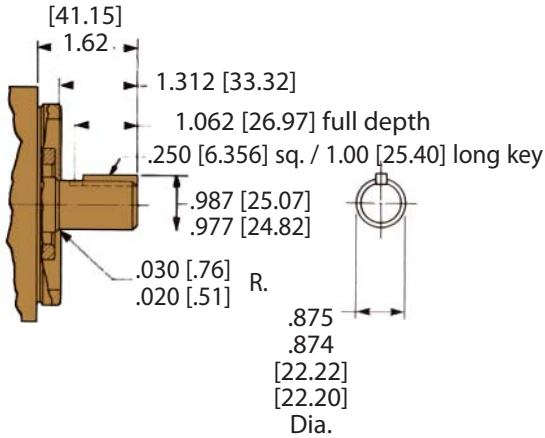

SAE "B" INVOLUTE SPLINE

Shaft No. 12: For F15, F1509 & F1515 Pumps
279.6 Nm (2475 in. lb.) torsional capacity.*

Flat Root - Side Fit
No. of Teeth - 13
Diametral Pitch - 16/32
Pressure Angle - 30°

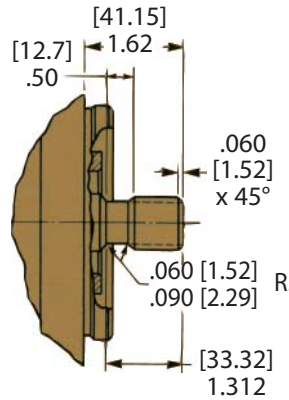

SAE "B-B" INVOLUTE SPLINE

Shaft No. 99: For F15, F1509, F1515 & F151515 Pumps
451.9 Nm (4000 in. lb.) torsional capacity.*

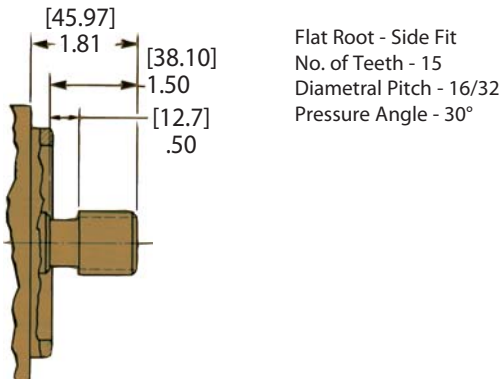

* Applies to coaxial applications only. Consult representative if application requires greater capacity or has side loads.

For shaft options not shown, contact factory for specific shaft information.

Technical Performance Data F15 Pumps

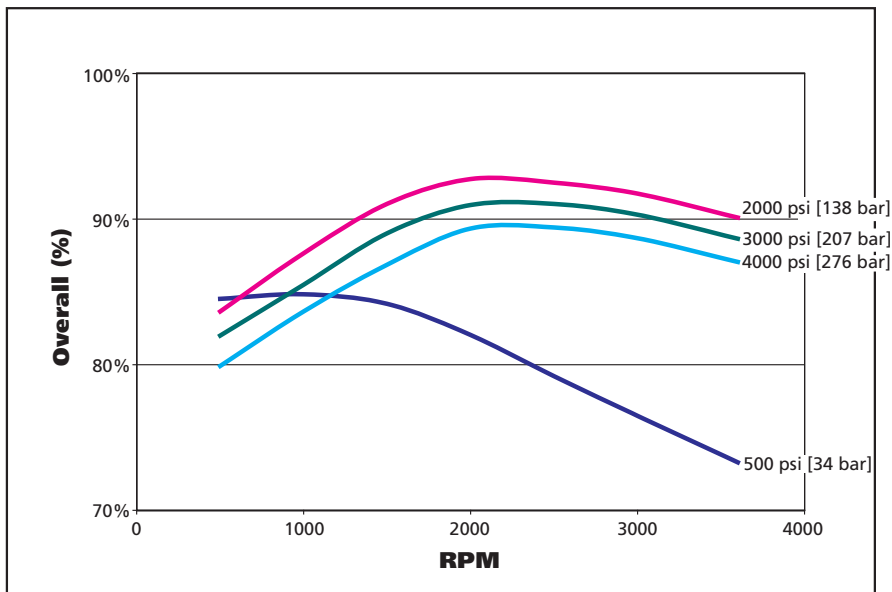
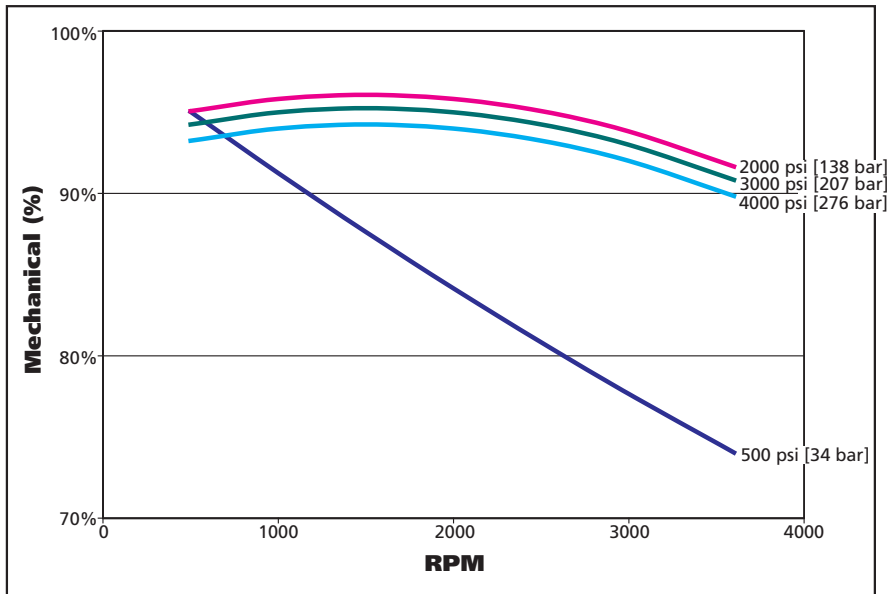
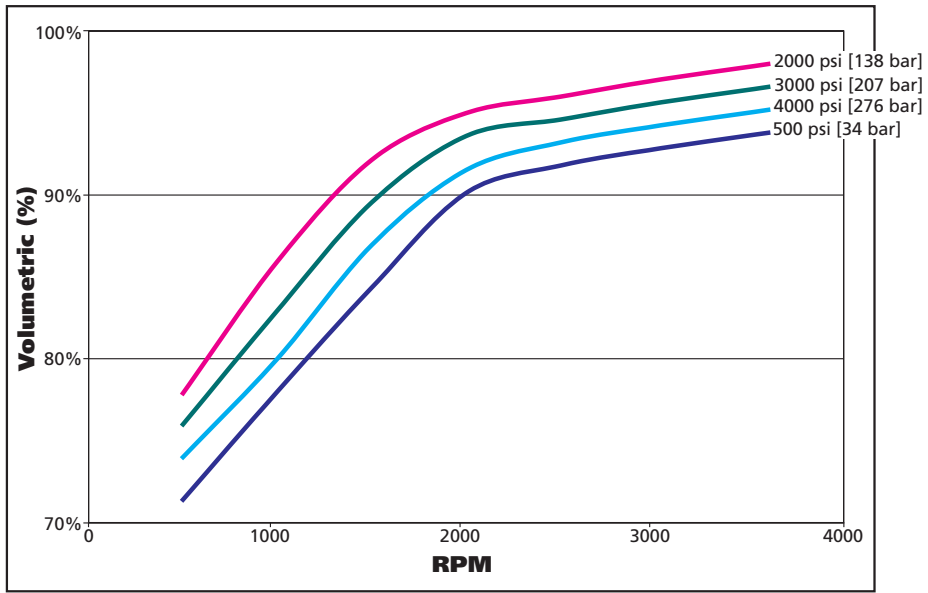

PUMPS & MOTORS

Cast Iron Pumps Heavy Duty



GC Series Pumps

Displacements
0.065 to 0.711 cu. In. (1.06 to 11.65 cc)

GC Series High/Low Pumps

High Pressure Displacements
0.065 to 0.258 cu. In. (1.06 to 4.22 cc)

Low Pressure Displacements
0.258 to 0.776 cu. In. (4.22 to 12.71 cc)

Maximum Pressure
4,000 psi (276 bar)

Maximum Speed
4,000 rpm



F12 & F15 Ferra Series Pumps

F12 Displacements
0.976 to 2.502 cu. In. (16 – 41 cc)

F15 Displacements
1.159 to 3.051 cu. In. (19 to 50 cc)

Maximum Pressure
4,000 psi (276 bar)

Maximum Speed
3,600 rpm



F20/F30 Pumps & F20-LS/F30-LS Load Sense Ferra Series Pumps

Displacements
1.41 to 9.82 cu. In. (23 to 161 cc)

Maximum Pressure
4,000 psi (276 bar)

Maximum Speed
3,600 rpm



D Series Pumps

Displacements
0.232 to 1.395 cu. In. (3.80 to 22.85 cc)

D Series High/Low Pumps

High Pressure Displacements
0.465 cu. In. (7.62 cc)

Low Pressure Displacements
0.930 to 1.395 cu. In. (15.24 to 22.86 cc)

Maximum Pressure
3,000 – 4,000 psi (207 – 276 bar)

Maximum Speed
3,600 – 4,000 rpm

Aluminum Pumps Medium/Light Duty



W-Series Pumps

W100 Displacements
0.031 to 0.122 cu. In. (0.50 to 2.00 cc)

W300 Displacements
0.049 to 0.347 cu. In. (0.80 to 5.70 cc)

W600 Displacements
0.244 to 0.732 cu. In. (4 to 12 cc)

W900 Displacements
0.305 to 1.891 cu. In. (5 to 31 cc)

W1200 Displacements
1.526 to 2.014 cu. In. (25 to 33 cc)

W1500 Displacements
1.159 to 3.051 cu. In. (19 to 50 cc)

Maximum Pressure
4,000 psi (276 bar)

Maximum Speed
500 to 4,000 rpm

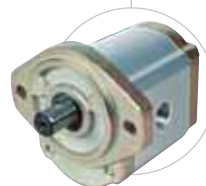

WQ900 Pumps

Displacements
0.305 to 1.648 cu. In. (5 to 27 cc)

Maximum Pressure
3,336 psi (230 bar)

Maximum Speed
4,000 rpm

Fluid Motors



Cast Iron

Displacements
0.065 to 9.82 cu. In. (1.06 to 161 cc)

Speed
Up to 10,000 rpm

Aluminum

Displacements
0.244 to 3.050 cu. In. (4 to 50 cc)

Speed
Up to 4,000 rpm

Flow Dividers



GC & D Series

GC Displacements
0.097 to 0.517 cu. In. (1.58 to 8.47 cc)

D Displacements
0.232 to 0.813 cu. in. (3.8 to 13.32 cc)

Maximum Pressure
4,500 psi (310 bar)

Maximum Input Flow Per Section
14 gpm (53 lpm)



Call us for more information

For application assistance or detailed literature on any Concentric product line, call us toll-free: **1-800-572-7867**.

Visit our web site: <http://www.concentricAB.com>

E-mail us: info.hydraulics.us@concentricAB.com

PRODUCT RANGE
HE Powerpacks

12/24/48 VDC 0.3 – 4.5 kW and
0.75 – 3 kW AC modular power packs

HE Box Powerpacks

12/24/48 VDC modular powerpacks
in weatherproof boxes

Pressure Switches

5 - 350 bar, connecting/disconnecting

W100 Hydraulic pumps

0,5 - 2,0 cc 227 bar

W300 Hydraulic pumps

0,8 – 5,7 cc 230 bar

W600 Hydraulic pumps / motors

3 – 12 cc 276 bar

W900 Hydraulic pumps / motors

5 – 31 cc/section 276 bar

Calma The new quiet pumps

6,2 - 23,7 cc/section 250 bar

WQ900 The quiet pumps

5 - 23 cc/section 230 bar

WP900X Hydraulic pumps

16 - 31 cc/section 276 bar

W1500 Hydraulic pumps / motors

19 - 50 cc/section 276 bar

F12 FERRA Heavy duty pumps

16 - 41 cc/section 276 bar

F15 FERRA Heavy duty pumps

19 - 50 cc/section 276 bar

F20/F30 (LS) Hydraulic pumps / motors

23 – 161 cc/section 276 bar

GPA Internal Gear pumps

1,7 – 63 cc/section 100 bar

GC Hydraulic pumps / motors

1,06 – 11,65 cc/section 276 bar

D Hydraulic pumps

3,8 – 22,9 cc/section 207 bar

H Hydraulic pumps

9,8 – 39,4 cc/section 207 bar

II-Stage Hydraulic pumps

4,2 – 22,8 cc/section 276 bar

Rotary Flow Dividers

3,8 – 13,3 cc/section 300 bar

Transmission pumps

www.concentricAB.com

Concentric Rockford Corp.

2222 15th Street
ROCKFORD, IL 61104
USA
Tel: +1-815 398 4400
Fax: +1-815 398 5977
E-mail: info.hydraulics.us@concentricAB.com

Concentric Hof GmbH

Postfach 1507
D-95014 HOF
Germany
Tel: +49-9281 895-0
Fax: +49-9281 87133
E-mail: info.hydraulics.eu@concentricAB.com

Concentric Skanes AB

Box 95
SE-280 40 SK. FAGERHULT
Sweden
Tel: +46-433 32400
Fax: +46-433 30546
E-mail: info.hydraulics.eu@concentricAB.com

Concentric Suzhou Co. Ltd.

47 Dongjing Industrial Park
9 Dong Fu Lu
SIP, Suzhou
Jiangsu
China 215123
Tel +86 512 8717 5100
Fax +86 512 8717 5101
info.chsh@concentricAB.com



Concentric is an innovator in flow control and fluid power, supplying proprietary systems and components for trucks, buses and industrial vehicles, worldwide. With 1,156 employees and yearly sales exceeding 1,977 million Swedish Kronor, Concentric AB is listed on the Stockholm Stock Exchange (www.concentricAB.com).

Concentric will not accept responsibility for any catalog errors and reserves the right to modify its products without prior notice. This also applies to products already ordered, provided that such modifications can be made without affecting technical specifications. All trademarks in this material are properties of their respective owners.